

INSTALLATION & SERVICE INFORMATION

Description

The FLOJET 2840 Series Water Booster System is designed to provide steady water pressure and generous water flow. The pump is fully automatic with a built-in switch and check valve to maintain system pressure and will supply smooth water flow from a trickle to full flow. Typically used in large yachts, motor homes & bus conversions where high volume flow is required for multiple fixtures and amenities (e.g. washing machine, dishwasher, ice maker and water purifier).

Product Data

Pump DesignQuad Diaphragm
MotorPermanent Magnet TENV
Wetted PartsDiaphragm Material.....Santoprene Check Valve Material.....EPDM Housing Material.....Polypropylene
Accumulator Tank	Diaphragm Material.....Butyl Liner Material.....Polypropylene
Ports3/4" (19 mm) HB Inlet1/2" (13 mm) HB Outlet
Net Weight2840-100 Type.....8.8 Pounds (4 kgs)2840-110 Type.....7.3 Pounds (3.3 kgs)2840-120 Type.....6.9 Pounds (3.1 kgs)

PERFORMANCE SPECIFICATIONS

Pump Motor

Max Amp Draw (A)	
(-100)	10.0 @ 12 Vdc
(-110)	8.5 @ 12 Vdc
(-120)	7.0 @ 12 Vdc
(-300)	5.0 @ 24 Vdc
(-400)	3.8 @ 32 Vdc
(-000)	1.5 @115 Vac

Priming	Dry.....10 ft (3 M)
	Wet.....20 ft (6 M)
Flow Rate	Max.....(-110) 3.5 GPM (13 LPM)
	Max.....(-120) 3.3 GPM (12 LPM)
	Max.....4.5 GPM (Others)
Pressure Switch	Off (-120) 35 PSI (2 bar); Others.....40 PSI (2.8 bar)
	On (-120) 22 PSI (1.5 bar); Others.....27 PSI (1.9 bar)

Tank

Total Volume1.1 gal. (4.1 lt.)
Air Pressure Setting25 PSI (1.7 bar)

Note: The 12, 24 and 32 VDC models meet the USCG Electrical Requirement (Title 33, Chapter I, Part 183, Subpart 1). All pumphead wetted materials meet IAPMO TSC-14-90 and TSC 31- 90 for potable water.

Models are available in 12 and 24 Volt models, and are identified by a prefix "R" and a CE mark on the label (i.e. R2840-100). Self Declaration Of Conformance (SDOC) is available upon request.

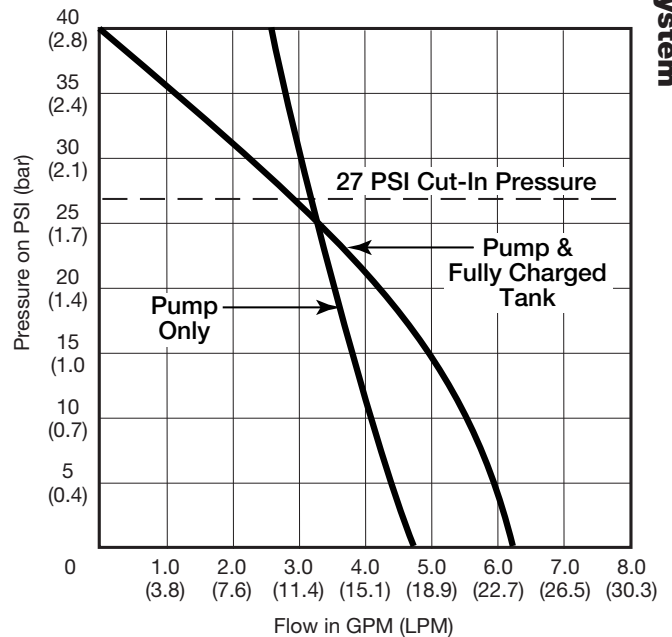

Dimensional Drawing Inches (Millimeters)

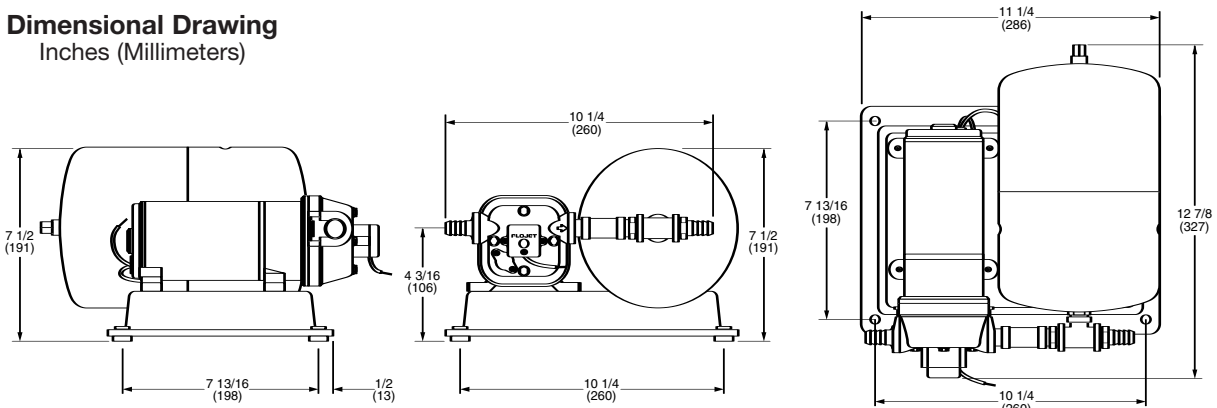

GENERAL SAFETY INFORMATION

Protect yourself and others by observing all safety information. Shut off power and drain pressure from system prior to service.

Mounting

The FLOJET 2840 Series Water Pressure System should be mounted in a dry and adequately ventilated area.

Select a location where the plumbing is as direct as possible and the inlet strainer is visible and accessible for cleaning.

The unit can be deck or bulkhead mounted. If bulkhead mounted, the pump head should be down or lower than the motor.

Fasten base securely with the four rubber mounting feet assembled to base as shown below.

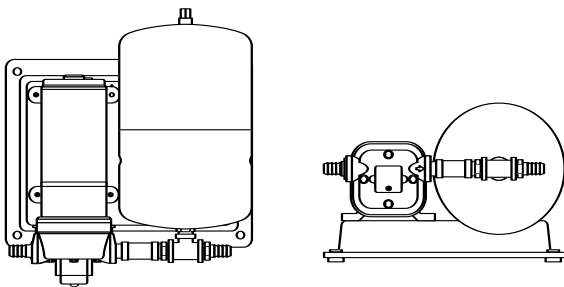

Vertical

Horizontal

Plumbing

Fasten strainer in a visible and accessible location for future cleaning. Use 3/4" (19 mm) I.D. hose between pump inlet & strainer. Connect strainer inlet to water supply line from tank and clamp all hose connections securely to avoid air leaks.

City water supply may be connected at any location in the pressurized cold water line.

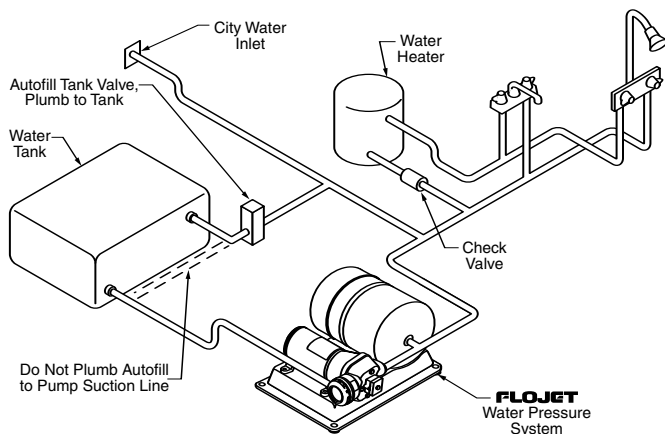

ELECTRICAL



WARNING



RISK OF AN ELECTRICAL SHOCK!

When wiring an electrically driven pump, follow all electrical and safety codes, as well as the most recent National Electrical Code (NEC) and the Occupational Safety and Health Act (OSHA).

RISK OF PRODUCT DAMAGE!

Make certain the power source conforms to the pump voltage. Be sure all power is disconnected before installation or removal.

For 12 VDC, 24 VDC and 32 VDC models, the red wire is positive and black is negative. Use the maximum recommended fuse for pump protection. Recommended fuse amp rating is located on pump label. Failure to provide correct overload device may result in motor failure.

For 115 VAC models plug AC cord into a conventional 115V AC outlet.

OPERATION

IMPORTANT - For correct operation, the tank must be properly pressurized on the air side **before** pump is started. Follow instructions on the tank label and check air pressure after filling and before starting the pump. The air valve is standard tire valve. Compressed air hose or hand pump may be used to pressurize. Pressure can be reduced by pressing the center pin in the valve.

To start up the Water Pressure System, make sure water supply tank is at least 1/4th full and is open to pump inlet. Open all valves or taps on outlet side to purge air from the system. Turn power on to the pump, pump will start up. Allow to pump for a minute or until all the air has been purged from the system. Close all valves in the system, the pump will pressurize the tank, shut off and operate automatically to maintain pressure in the system.

To completely fill the pressure tank for maximum volume, shut off power to pump and open faucet (or valve) closest to tank. Trapped air will be expelled. Turn on power to pump.



WARNING



DO NOT USE PUMP IN A FLAMMABLE ENVIRONMENT DO NOT USE TO PUMP FLAMMABLE OR EXPLOSIVE FLUIDS SUCH AS GASOLINE, FUEL OIL, KEROSENE, ETC.

! WARNING: DISCONNECT POWER TO PUMP AND OPEN VALVE TO RELIEVE WATER PRESSURE PRIOR TO SERVICING PUMP !

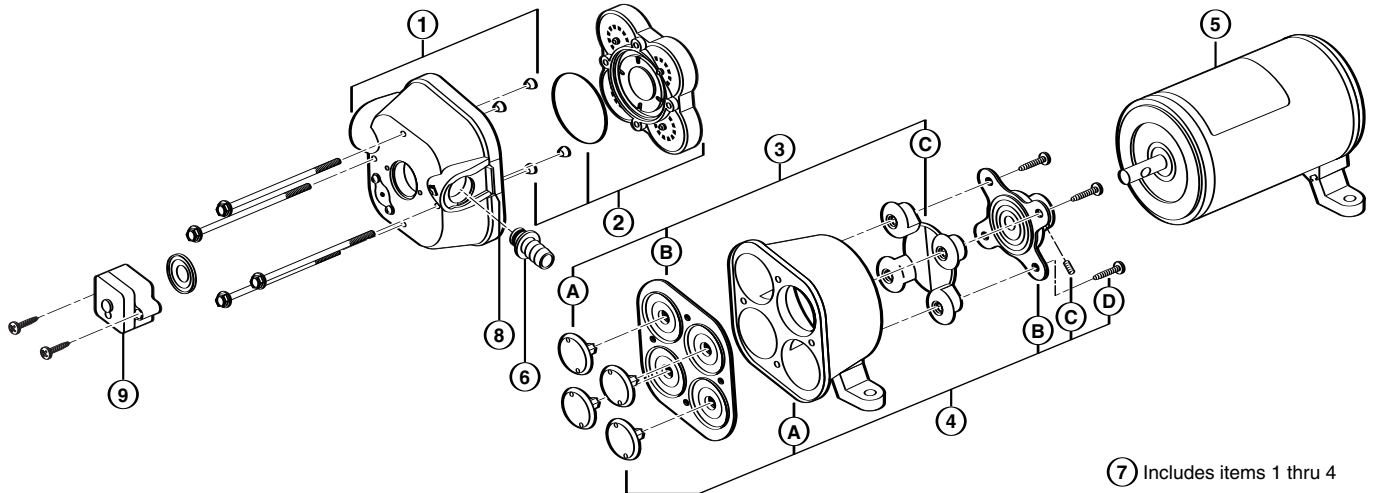

⑦ Includes items 1 thru 4

Key	Part No.	Description	Qty
0	20409-043	Service Kit*	
1	20404-003	Upper Housing Assy Kit	1
2	20407-030	Check Valve Kit - EPDM w/O-Ring & Ferrules	1
3	20403-040	Diaphragm Kit, Santo w/Pistons & Screws	1
4	20419-002	Lower Housing	1
5	02009-080A	Motor 12 Volt DC 2840-100	1
	02009-087A	Motor 12 Volt DC 2840-110	1
	02009-073A	Motor 12 Volt DC 2840-120	1
	02019-027A	Motor 24 Volt DC 2840-300	1
	02049-026A	Motor 32 Volt DC 2840-400	1
	02029-091A	Motor 115 Volt AC 2840-000	1
"	20799-000A	Accumulator Tank	1

*Service Kit includes #2, #3, #8 and drive cam assembly.

Key	Part No.	Description	Qty
"	120796-000A	Base	1
6	20381-022	Port Kit - (set of 2)	
		Hose Barb, 90° 3/4"	1
		Hose Barb, Straight 3/4"	1
7	20406-002A	Pump Head Assy.	1
8	20408-000	Port Clips (Set of 2)	1
9	02090-118	Pressure Switch - 40 PSI Off, Sealed	1
"	04325-143A	Complete MPU w/Strainer - 12V 4.5 GPM	1
"	04305-144A	Complete MPU w/Strainer - 12V 3.5 GPM	1
"	04305-500A	Complete MPU w/Strainer - 12V 3.3 GPM	1
"	04325-343A	Complete MPU w/Strainer - 24V 4.5 GPM	1
"	04325-443A	Complete MPU w/Strainer - 32V 4.5 GPM	1
"	04325-043A	Complete MPU w/Strainer - 115V 4.5 GPM	1
"	01740-000	Strainer, Inline 3/4" Hose Barb	1

DISASSEMBLE

Pressure Switch (9)

1. Disconnect power to pump and open a faucet or valve to relieve system pressure.
2. Remove the two visible Pressure Switch Screws located on each side of the Pressure Switch (9). DO NOT ADJUST ALLEN HEAD SCREW IN CENTER OF SWITCH.

Upper Housing (1)

3. Loosen but DO NOT remove the four Pump Head Screws and carefully remove Upper Housing Assembly (1).
4. Slide Port Clip (8) back and unplug from Tank Plumbing.
5. Remove Check Valve (2) and inspect for debris.

Check Valve Assembly (2) Follow Steps 1, 3 & 4

6. Inspect Check Valve (2) and O-Ring

Lower Housing (4) Follow Step 1

7. Remove pump from both Base and Tank Plumbing.
8. Remove Rubber Feet by pulling out and sliding to the rear and follow step 3.
9. Rotate Lower Housing (4), so access Rubber Grommet foot notch is aligned with Cam Bearing Set Screw (4-C), loosen set screw with a 1/8" Allen Wrench and slide pump head off motor shaft.

Diaphragm (3-B)

10. Loosen four cam piston screws with Phillips head screw driver and pull apart cam (4-B) from Inner Pistons (3-A). (Both pistons (3-A & C) should be replaced when a new Diaphragm (3-13) is installed.)

Motor (5) Follow Steps 1, 7, 8 & 9

REASSEMBLE

Diaphragm (3-B)

1. Insert Outer Pistons (3-C) into Lower Housing (4-A) by bending pistons at center fold.
2. Placing the Diaphragm (3-B) (flatter side of Diaphragm facing the motor) on the Lower Housing (4-A). Press each Inner Piston (3-A) through the Diaphragm and Lower Housing (4-A) into Outer Piston (3-C). Hex stem of Inner Pistons (3-A) must be aligned into hex holes in Outer Pistons (3-C). Tighten cam piston screws partially, center piston in diaphragm, and tighten screws securely (18 in. lbs. torque). Also, the Outer Pistons (3-C) must be aligned with alignment slots on Cam Assembly (4-B) making sure screw holes align in cam assembly, otherwise diaphragm will leak.

Cam Bearing (4-B)

3. Place Cam Bearing (4-B) over Inner Pistons (3-C) and tighten down with four Phillips Head Screws. (18 in. lbs. torque)

Lower Housing (4) to Motor (6)

- Coat motor shaft with grease prior to installing Cam Bearing (4-B).
4. When installing the Lower Housing (4), rotate mounting foot notch to align with Cam Bearing Set Screw (4-C).
5. Attach Cam Bearing (4-B) to motor shaft indentation with Cam Bearing Set Screw (4-C). (35 in. lbs. torque)
6. Reinsert Rubber Feet.

Check Valve (2)

7. Place Ferrules (Rubber Cones) in the Upper Housing (1) coned side first.
8. Properly seat O-Ring in Check Valve (2) and insert Check Valve (2) into the Upper Housing (1).

Upper Housing (1)

9. Place Upper Housing (1) on top of the Lower Housing (4-A) and tighten Hex Bolts (30 in. lbs. torque) through the Upper Housing (1) to the Motor.

TROUBLESHOOTING CHART

Symptom	Possible Cause(s)	Corrective Action
Pump will not prime or retain prime after operating	<ul style="list-style-type: none"> Air leak in suction line Defective check valve Upper housing leaking Suction lift too high Debris in check valve(s) 	<ul style="list-style-type: none"> Repair or replace Replace Tighten bolts Lower pump Clean check valve(s)
Pump runs but no fluid	<ul style="list-style-type: none"> Faulty suction piping Defective check valve Suction lift too high Clogged inlet Inlet line valve closed 	<ul style="list-style-type: none"> Repair or replace Replace Lower pump Clean or replace Open valve
Motor runs too hot	<ul style="list-style-type: none"> Voltage incorrect Insufficient ventilation for motor 	<ul style="list-style-type: none"> Check voltage Insure proper ventilation
Flow rate is low	<ul style="list-style-type: none"> Piping or hose is damaged Clogged check valve Worn check valve Voltage incorrect Tank over pressurized 	<ul style="list-style-type: none"> Clean or replace Clear obstruction Replace Check voltage Check tank pressure
Pump leaks	<ul style="list-style-type: none"> Upper housing loose Pistons loose Pump head loose on motor Switch loose Defective Diaphragm 	<ul style="list-style-type: none"> Tighten screws Tighten pistons Tighten pump head Tighten switch Replace
Pump will not run	<ul style="list-style-type: none"> No electricity Defective pressure switch Motor has open circuit Thermal protector has cut off 	<ul style="list-style-type: none"> Check connections, fuse, breakers Replace switch Replace Allow motor to cool 15-30 min

CONVERSION TABLE

TO CONVERT	TO	MULTIPLY BY
Gallons, U.S.	Liters	3.785
Liters	Gallons, U.S.	0.264
Pounds/Sq. Inch	Bar	0.069
Bar	Pounds/Sq. Inch	14.5
Fahrenheit	Celsius	(°F-32) .556
Celsius	Fahrenheit	(°C X 1.8) + 32

WARRANTY

FLOJET warrants this product to be free of defects in material and/or workmanship for a period of one year after purchase by the customer from FLOJET. During this one year warranty period, FLOJET will at its option, at no charge to the customer, repair or replace this product if found defective in material or workmanship, with a new or reconditioned product, but not to include costs of removal or installation.

This is only an overview of our limited warranty. If you would like a copy of our warranty, please call or write FLOJET.

RETURN PROCEDURE

Prior to returning any product to FLOJET, call customer service for an authorization number. This number must be written on the outside of the shipping package. Place a note inside the package with an explanation regarding the reason for return as well as the authorization number. Include your name, address and phone number.

Flojet

www.flojet.com



ITT Industries
Engineered for life

U.S.A.
Flojet
20 Icon
Foothill Ranch, CA 92610
Tel: 949.859.4945
Fax: 949.859.1153

UNITED KINGDOM
Flojet
Bingley Road, Hoddesdon
Hertfordshire EN11 OBU
Tel: +44 (0) 1992 450145
Fax: +44 (0) 1992 467132

CANADA
Fluid Products Canada
55 Royal Road
Guelph, Ontario N1H 1T1
Tel: 519 821.1900
Fax: 519 821.2569

JAPAN
NHK Jabsco Company Ltd.
3-21-10, Shin-Yokohama
Kohoku-Ku, Yokohama, 222
Tel: 045.475.8906
Fax: 045.475.8908

GERMANY
Jabsco GmbH
Oststrasse 28
22840 Norderstedt
Tel: +49-40-53 53 73 -0
Fax: +49-40-53 53 73 -11

ITALY
Jabsco Marine Italia
Via Tommaseo, 6
20059 Vimercate, Milano
Tel: +39 039 685 2323
Fax: +39 039 666 307